



Inhaltsverzeichnis

Präzisions- Stahlplatten

Artikel	Artikel- Nr.	Seite
Anwendungsbeispiele für Präzisions-Stahlplatten		2
Präzisions- Stahlplatten (1.1730/ St 52-3)	P 1301	3 - 5



Präzisions- Stahlplatten

> P 1301

Anwendungsbeispiele für Präzisions- Stahlplatten:

Präz.- Barren B 2201

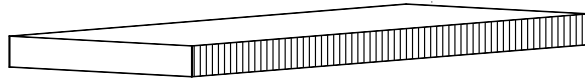

Präz.- Stahlplatte P 1301



P- Platten für Säulengestelle

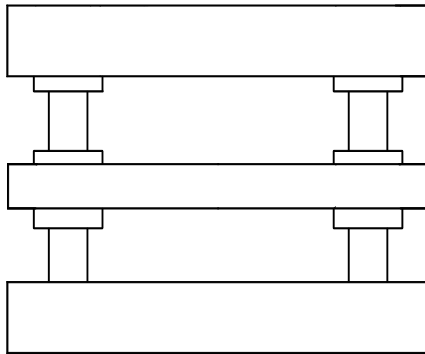

P- Platten für Folgewerkzeuge

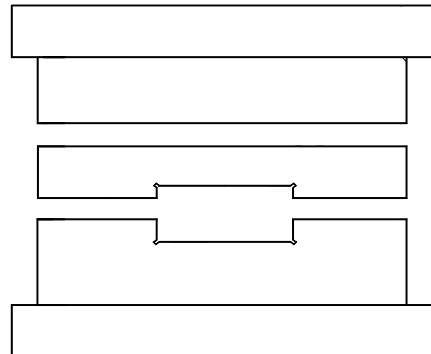

P- Platten für Formenaufbauten

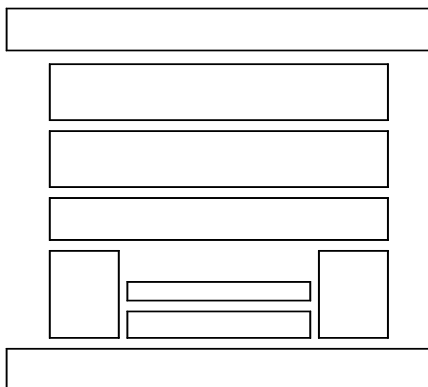

P- Platten mit Sonderbearbeitungen wie Bohrungen und Durchbrüche

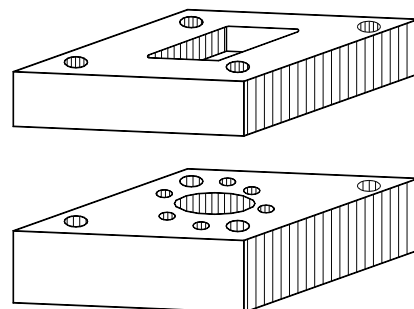

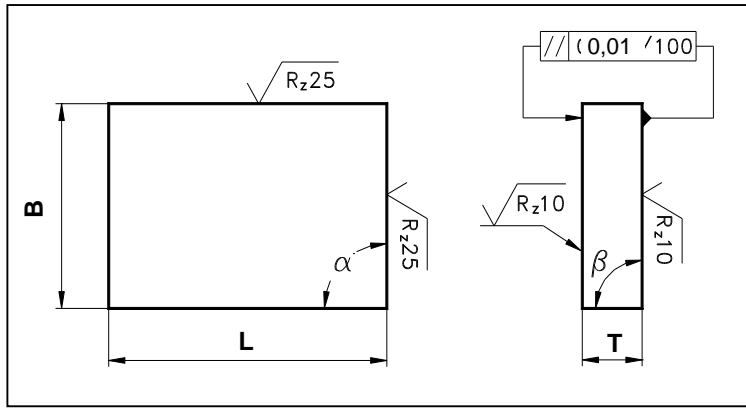

B + L - 0/ +0,20 mm
T + 0,20/ +0,35 mm

α ≤ + 0,02/ 100 mm
β ≤ + 0,02/ 100 mm

B	L	T	P 1301.	€/ Stk	B	L	T	P 1301.	€/ Stk	B	L	T	P 1301.	€/ Stk				
156	196	17	1620 x 17	47,00	196	346	17	2035 x 17	84,20	246	346	56	2535 x 56	152,10				
		22	1620 x 22	51,10			22	2035 x 22	89,70			76	2535 x 76	193,50				
		27	1620 x 27	53,90			27	2035 x 27	98,00			96	2535 x 96	232,30				
		36	1620 x 36	54,30			36	2035 x 36	100,00			116	2535 x 116	273,70				
		46	1620 x 46	59,30			46	2035 x 46	107,30									
		56	1620 x 56	66,40			56	2035 x 56	127,40	246	396	17	2540 x 17	114,60				
		76	1620 x 76	82,30			76	2035 x 76	156,00	22	2540 x 22	120,10						
													27	2540 x 27	128,40			
													36	2540 x 36	137,20			
156	246	17	1625 x 17	55,20	196	396	17	2040 x 17	95,30	46	2540 x 46	149,40						
		22	1625 x 22	59,40			22	2040 x 22	100,80	56	2540 x 56	171,50						
		27	1625 x 27	64,90			27	2040 x 27	109,10	76	2540 x 76	213,00						
		36	1625 x 36	67,70			36	2040 x 36	110,40	96	2540 x 96	254,30						
		46	1625 x 46	73,10			46	2040 x 46	121,90	116	2540 x 116	301,20						
		56	1625 x 56	81,60			56	2040 x 56	142,00									
76	1625 x 76	102,20	76	2040 x 76	177,50	246	496	22	2550 x 22	144,90								
													27	2550 x 27	154,60			
													36	2550 x 36	159,10			
196	196	17	2020 x 17	55,20	246	246	17	2525 x 17	77,30	46	2550 x 46	174,80						
		22	2020 x 22	59,40			22	2525 x 22	82,80	56	2550 x 56	198,90						
		27	2020 x 27	64,00			27	2525 x 27	88,40	76	2550 x 76	245,70						
		36	2020 x 36	67,10			36	2525 x 36	91,70	96	2550 x 96	292,50						
		46	2020 x 46	73,10			46	2525 x 46	101,20	116	2550 x 116	346,80						
		56	2020 x 56	81,90			56	2525 x 56	115,20									
		76	2020 x 76	102,60			76	2525 x 76	146,10	296	296	17	3030 x 17	103,50				
96	2020 x 96	125,30	96	2525 x 96	175,40	22	3030 x 22	109,10										
													27	3030 x 27	117,30			
													36	3030 x 36	123,30			
196	246	17	2025 x 17	64,90	246	296	17	2530 x 17	91,10	46	3030 x 46	134,70						
		22	2025 x 22	70,40			22	2530 x 22	95,30	56	3030 x 56	155,90						
		27	2025 x 27	74,60			27	2530 x 27	100,80	76	3030 x 76	196,80						
		36	2025 x 36	76,90			36	2530 x 36	107,10	116	3030 x 116	279,10						
		46	2025 x 46	84,50			46	2530 x 46	117,40									
		56	2025 x 56	95,90			56	2530 x 56	136,00	296	346	17	3035 x 17	117,30				
76	2025 x 76	102,60	76	2530 x 76	167,40	22	3035 x 22	122,90										
96	2025 x 96	145,40	96	2530 x 96	200,80	27	3035 x 27	131,10										
													36	3035 x 36	138,60			
													46	3035 x 46	152,70			
196	296	17	2030 x 17	74,60	246	346	17	2535 x 17	103,50	56	3035 x 56	174,80						
		22	2030 x 22	81,50			22	2535 x 22	107,70	76	3035 x 76	216,30						
		27	2030 x 27	85,60			27	2535 x 27	114,60	96	3035 x 96	258,50						
		36	2030 x 36	91,70			36	2535 x 36	120,30	116	3035 x 116	305,90						
		46	2030 x 46	101,20			46	2535 x 46	132,00									
		56	2030 x 56	113,30														
		76	2030 x 76	144,00														
96	2030 x 96	174,80																



Präzisions- Stahlplatten

Werkstoff 1.1730/ St 52-3

Breite und Länge feinstgefräst, Auflageflächen geschliffen

ARTIKEL-Nr.					ARTIKEL-Nr.					ARTIKEL-Nr.				
B	L	S	P 1301.	€/ Stk	B	L	S	P 1301.	€/ Stk	B	L	S	P 1301.	€/ Stk
296	396	22	3040 x 22	136,70	346	446	22	3545 x 22	171,20	396	596	27	4060 x 27	267,80
		27	3040 x 27	149,10			27	3545 x 27	183,60			36	4060 x 36	278,10
		36	3040 x 36	154,00			36	3545 x 36	195,30			46	4060 x 46	289,20
		46	3040 x 46	169,40			46	3545 x 46	207,60			56	4060 x 56	329,30
		56	3040 x 56	193,50			56	3545 x 56	236,30			76	4060 x 76	414,20
		76	3040 x 76	240,30			76	3545 x 76	291,80			96	4060 x 96	491,20
		96	3040 x 96	285,80			96	3545 x 96	348,70			116	4060 x 116	574,70
116	3040 x 116	336,70	116	3545 x 116	403,60									
296	446	22	3045 x 22	153,20	346	496	22	3550 x 22	186,30	446	446	27	4545 x 27	229,10
		27	3045 x 27	162,90			27	3550 x 27	200,10			36	4545 x 36	237,10
		36	3045 x 36	169,60			36	3550 x 36	214,30			46	4545 x 46	250,30
		46	3045 x 46	185,50			46	3550 x 46	227,00			56	4545 x 56	285,80
		56	3045 x 56	210,90			56	3550 x 56	256,40			76	4545 x 76	356,00
		76	3045 x 76	261,00			76	3550 x 76	317,20			96	4545 x 96	424,30
		96	3045 x 96	311,90			96	3550 x 96	378,70			116	4545 x 116	495,80
116	3045 x 116	366,80	116	3550 x 116	441,00									
296	496	22	3050 x 22	167,00	346	596	22	3560 x 22	219,50	446	496	27	4550 x 27	251,20
		27	3050 x 27	178,10			27	3560 x 27	234,60			36	4550 x 36	262,50
		36	3050 x 36	183,60			36	3560 x 36	248,20			46	4550 x 46	272,50
		46	3050 x 46	200,80			46	3560 x 46	257,80			56	4550 x 56	310,50
		56	3050 x 56	227,70			56	3560 x 56	293,90			76	4550 x 76	388,80
		76	3050 x 76	281,20			76	3560 x 76	366,80			96	4550 x 96	463,00
		96	3050 x 96	335,90			96	3560 x 96	437,60			116	4550 x 116	538,60
116	3050 x 116	391,50	116	3560 x 116	512,60									
296	596	27	3060 x 27	208,40	396	396	22	4040 x 22	175,30	446	596	27	4560 x 27	291,20
		36	3060 x 36	237,40			27	4040 x 27	186,30			36	4560 x 36	305,10
		46	3060 x 46	254,00			36	4040 x 36	200,40			46	4560 x 46	316,60
		56	3060 x 56	287,90			46	4040 x 46	209,50			56	4560 x 56	335,30
		76	3060 x 76	324,60			56	4040 x 56	238,30			76	4560 x 76	451,70
		96	3060 x 96	386,90			76	4040 x 76	294,60			96	4560 x 96	542,60
		116	3060 x 116	452,30			96	4040 x 96	352,10			116	4560 x 116	624,50
					116	4040 x 116	388,80							
346	346	22	3535 x 22	142,20	396	446	22	4045 x 22	193,20	446	696	27	4570 x 27	332,60
		27	3535 x 27	150,50			27	4045 x 27	205,70			36	4570 x 36	349,40
		36	3535 x 36	156,90			36	4045 x 36	219,50			46	4570 x 46	362,80
		46	3535 x 46	171,50			46	4045 x 46	231,70			56	4570 x 56	410,80
		56	3535 x 56	195,50			56	4045 x 56	262,40			76	4570 x 76	504,80
		76	3535 x 76	243,00			76	4045 x 76	321,70			96	4570 x 96	601,20
116	3535 x 116	342,00	96	4045 x 96	387,50	116	4570 x 116	700,10						
					116	4045 x 116	453,00							
346	396	22	3540 x 22	156,00	396	496	22	4050 x 22	209,80	496	496	27	5050 x 27	270,50
		27	3540 x 27	167,00			27	4050 x 27	223,60			46	5050 x 46	295,90
		36	3540 x 36	178,00			36	4050 x 36	235,70			56	5050 x 56	338,00
		46	3540 x 46	189,50			46	4050 x 46	249,00			76	5050 x 76	423,00
		56	3540 x 56	216,90			56	4050 x 56	284,50			96	5050 x 96	506,50
		76	3540 x 76	267,70			76	4050 x 76	354,00			116	5050 x 116	588,80
		96	3540 x 96	318,50			96	4050 x 96	422,20					
116	3540 x 116	375,40	116	4050 x 116	492,50									

**Präzisions- Stahlplatten**

Werkstoff 1.1730/ St 52-3

Breite und Länge feinstgefräst, Auflageflächen geschliffen

B	L	T	P 1301.	€/ Stk	B	L	T	P 1301.	€/ Stk	B	L	T	P 1301.	€/ Stk
496	546	27	5055 x 27	295,40	546	546	36	5555 x 36	309,90	596	596	36	6060 x 36	365,60
		36	5055 x 36	306,30			46	5555 x 46	343,40			46	6060 x 46	413,50
		46	5055 x 46	315,70			56	5555 x 56	392,50			56	6060 x 56	462,20
		56	5055 x 56	360,40			66	5555 x 66	441,60			66	6060 x 66	536,30
		76	5055 x 76	450,30			76	5555 x 76	493,50			76	6060 x 76	580,20
		96	5055 x 96	538,90			96	5555 x 96	591,30			96	6060 x 96	702,10
		116	5055 x 116	628,70			116	5555 x 116	689,10			116	6060 x 116	824,90
496	596	27	5060 x 27	318,80	546	596	36	5560 x 36	351,20	596	696	36	6070 x 36	441,10
		36	5060 x 36	338,00			46	5560 x 46	370,20			46	6070 x 46	494,90
		46	5060 x 46	368,90			56	5560 x 56	425,30			56	6070 x 56	567,10
		56	5060 x 56	390,60			66	5560 x 66	481,80			66	6070 x 66	625,60
		76	5060 x 76	487,70			76	5560 x 76	533,60			76	6070 x 76	710,70
		96	5060 x 96	586,10			96	5560 x 96	642,50			96	6070 x 96	851,90
		116	5060 x 116	685,10			116	5560 x 116	752,70			116	6070 x 116	1006,90
496	696	27	5070 x 27	363,00	546	696	36	5570 x 36	406,40	596	796	36	6080 x 36	518,50
		36	5070 x 36	385,10			46	5570 x 46	469,30			46	6080 x 46	561,90
		46	5070 x 46	397,20			56	5570 x 56	530,90			56	6080 x 56	646,30
		56	5070 x 56	449,00			66	5570 x 66	589,70			66	6080 x 66	738,00
		76	5070 x 76	563,80			76	5570 x 76	659,60			76	6080 x 76	832,10
		96	5070 x 96	681,30			96	5570 x 96	819,60			96	6080 x 96	979,80
		116	5070 x 116	796,10			116	5570 x 116	899,30			116	6080 x 116	1142,50
496	796	27	5080 x 27	407,10	546	796	36	5580 x 36	479,80	596	896	36	6090 x 36	609,70
		36	5080 x 36	435,40			46	5580 x 46	538,20			46	6090 x 46	660,90
		46	5080 x 46	469,30			56	5580 x 56	597,20			56	6090 x 56	717,30
		56	5080 x 56	543,40			66	5580 x 66	673,80			66	6090 x 66	826,90
		76	5080 x 76	704,20			76	5580 x 76	768,50			76	6090 x 76	916,00
		96	5080 x 96	813,70			96	5580 x 96	896,40			96	6090 x 96	1120,80
		116	5080 x 116	929,90			116	5580 x 116	1014,30			116	6090 x 116	1285,30

Stahlqualität: Werkstoff- Nr.: 1.1730
DIN- Bezeichnung: C 45 W
Richtanalyse: C-0,45 Si-0,30 Mn-0,70
Festigkeit: ca. 640 N/ mm²
Charakteristik: Unlegierter Werkzeugstahl
Verwendungsbeispiele: Ungehärtete Bauteile für den Formen-, Werkzeug- und Vorrichtungsbau

Bestellbeispiel: Präzisions- Stahlplatte **P 1301**
Breite **B**= 396 mm, Länge **L**= 596 mm, Dicke **T**= 46 mm
P 1301. 4060 x 46

Andere Abmessungen auf Anfrage.